

INDUSTRIAL PIPE CLAMPTyp **3567 A**

with rounded ends, dimensions according to DIN 3567 A

dipa



Also **STAINLESS** available
RUST PROOF

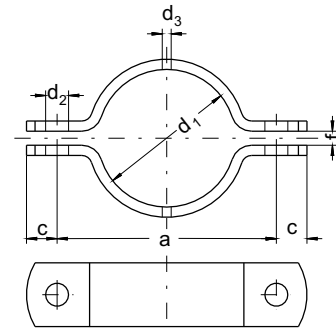

d ₁	usage at nominal diameters		a	c	d ₂	f	Steel mm	Accessories: Hexagon head screws	kg per 100 pair without screws	d ₃	
20 22	15	1/2"	57 59	15	11,5	7	30x5	M10x30 Mu	19 20	ohne	
25 27	20	3/4"	62 66						21 22		
30 34	25	1"	66 68						23 24		
38 43	32	1 1/4"	76 82						26 27		
45 49	40	1 1/2"	84 88						28 30		
57 61	50	2"	104 108	18	14	9	40x6	M12x35 Mu	56 58		
70 77	65	2 1/2"	115 122						63 66		
89	80	3"	136						75		
108 115	100	4"	172 178	24	18	11	50x8	M16x45 Mu	159 163		7
133 140	125		196 204						178 183		
159 169	150		222 232						200 208		
191 194	175		254 258						239 242		
216 220	200		280 284						260 264		
267 273	250		342 348	30	23	14	60x8	M20x50 Mu	385 390		
318 324	300		392 398						440 448		
356 368	350		432 444						508 530		
407 419	400		498 510	36	27	18	80x8*	M24x60 Mu	852 875	11	
457	450		548						940		
508 521	500		600 614						1020 1050		
610	600		717				1600				
711	700		812				2700				
813	800		913				3050				
915	900		1016				3340				
1016	1000		1119				3600				
									100x12*		

Specification

Material No. 1.0038, Surface: ordinary steel, hot-dip galvanized or stainless steel material-No. 1.4301 or 1.4571

07.17